



✓ UMA - Unidad Manejadora de Aire Hidrónica | Horizontal

220V-3F-60HZ - Agua Helada | 460V-3F-60HZ - Agua Helada



*Imágenes con fines ilustrativos.

Capacidades:

220V			460V		
IAHWH-06KF-5	5	TR.	IAHWH-06KF-6	5	TR.
IAHWH-08KF-5	7.5	TR.	IAHWH-08KF-6	7.5	TR.
IAHWH-12KF-5	10	TR.	IAHWH-12KF-6	10	TR.
IAHWH-14KF-5	12.5	TR.	IAHWH-14KF-6	12.5	TR.
IAHWH-16KF-5	15	TR.	IAHWH-16KF-6	15	TR.
IAHWH-24KF-5	20	TR.	IAHWH-24KF-6	20	TR.
IAHWH-28KF-5	25	TR.	IAHWH-28KF-6	25	TR.
IAHWH-34KF-5	30	TR.	IAHWH-34KF-6	30	TR.

Características del Equipo:

- ✓ Descarga y retorno de aire horizontal.
- ✓ Paneles doble pared con poliuretano inyectado.
- ✓ Incluye base de suspensión incluida de fábrica.
- ✓ Incluye caja de control y arranque.
- ✓ Serpentin con tubos de cobre y aletas de aluminio.
- ✓ Puerta de servicio para acceso al motor del equipo.
- ✓ Incluye bancos de filtros de aluminio lavables de fábrica.
- ✓ Equipo cuenta con serpentin de 6 hileras para una mayor eficiencia.
- ✓ Modos de operación enfriamiento y calefacción con agua helada o agua caliente.

Características Técnicas:

✓ DATOS ELÉCTRICOS EQUIPO 220V.

Modelo	Capacidad (TR)	Información eléctrica		
		Alimentación (V, F, Hz)	Consumo (A)	Tamaño Motor (HP)
IAHWH-06KF-5	5	220, 3, 60	6.0	2.0
IAHWH-08KF-5	7.5	220, 3, 60	8.2	3.0
IAHWH-12KF-5	10	220, 3, 60	8.2	3.0
IAHWH-14KF-5	12.5	220, 3, 60	11.1	4.0
IAHWH-16KF-5	15	220, 3, 60	11.1	4.0
IAHWH-24KF-5	20	220, 3, 60	19.7	7.4
IAHWH-28KF-5	25	220, 3, 60	19.7	7.4
IAHWH-34KF-5	30	220, 3, 60	19.7	7.4

✓ DATOS ELÉCTRICOS EQUIPO 460V.

Modelo	Capacidad (TR)	Información eléctrica		
		Alimentación (V, F, Hz)	Consumo (A)	Tamaño Motor (HP)
IAHWH-06KF-6	5	460, 3, 60	2.9	2.0
IAHWH-08KF-6	7.5	460, 3, 60	3.9	3.0
IAHWH-12KF-6	10	460, 3, 60	3.9	3.0
IAHWH-14KF-6	12.5	460, 3, 60	5.3	4.0
IAHWH-16KF-6	15	460, 3, 60	5.3	4.0
IAHWH-24KF-6	20	460, 3, 60	9.4	7.4
IAHWH-28KF-6	25	460, 3, 60	9.4	7.4
IAHWH-34KF-6	30	460, 3, 60	9.4	7.4



☑ DATOS GENERALES

Modelo	Capacidad (TR)	Capacidad de Enfriamiento (Btus/h)	Capacidad de Calefacción (Btus/h)	Serpentín Hileras	Flujo de Agua (GPM)	Caída de Presión (kPa)	Tuberías de Agua (Sum y Return) [DN mm] (In)	Tubería de Drenado [DN mm] (In)
IAHWH-06KF-5/6	5	61,416	95,536	6	13.63	62	[DN40] (1.5")	[DN25] (1.0")
IAHWH-08KF-5/6	7.5	92,124	122,832	6	20.44	40	[DN40] (1.5")	[DN25] (1.0")
IAHWH-12KF-5/6	10	122,832	156,952	6	27.26	61	[DN40] (1.5")	[DN25] (1.0")
IAHWH-14KF-5/6	12.5	150,128	191,072	6	33.44	59	[DN50] (2.0")	[DN25] (1.0")
IAHWH-16KF-5/6	15	180,836	218,368	6	40.25	58	[DN50] (2.0")	[DN25] (1.0")
IAHWH-24KF-5/6	20	242,252	279,784	6	53.89	33	[DN50] (2.0")	[DN25] (1.0")
IAHWH-28KF-5/6	25	300,256	341,200	6	66.73	33	[DN50] (2.0")	[DN25] (1.0")
IAHWH-34KF-5/6	30	368,496	402,616	6	81.94	33	[DN50] (2.0")	[DN25] (1.0")

☑ DESEMPEÑO

Modelo	Capacidad (TR)	Volumen de Aire (CFM)	Presión Estática Externa [Pa] (In wg)	Nivel de Ruido (dBA)	Peso (Kg)
IAHWH-06KF-5/6	5	2,000	[350] (1.41")	76	144
IAHWH-08KF-5/6	7.5	3,000	[350] (1.41")	75	170
IAHWH-12KF-5/6	10	4,000	[350] (1.41")	73	205
IAHWH-14KF-5/6	12.5	5,000	[300] (1.21")	74	250
IAHWH-16KF-5/6	15	6,000	[300] (1.21")	73	280
IAHWH-24KF-5/6	20	8,000	[350] (1.41")	77	380
IAHWH-28KF-5/6	25	8,800	[400] (1.61")	78	380
IAHWH-34KF-5/6	30	8,800	[400] (1.61")	78	380

☑ Diagrama eléctrico:

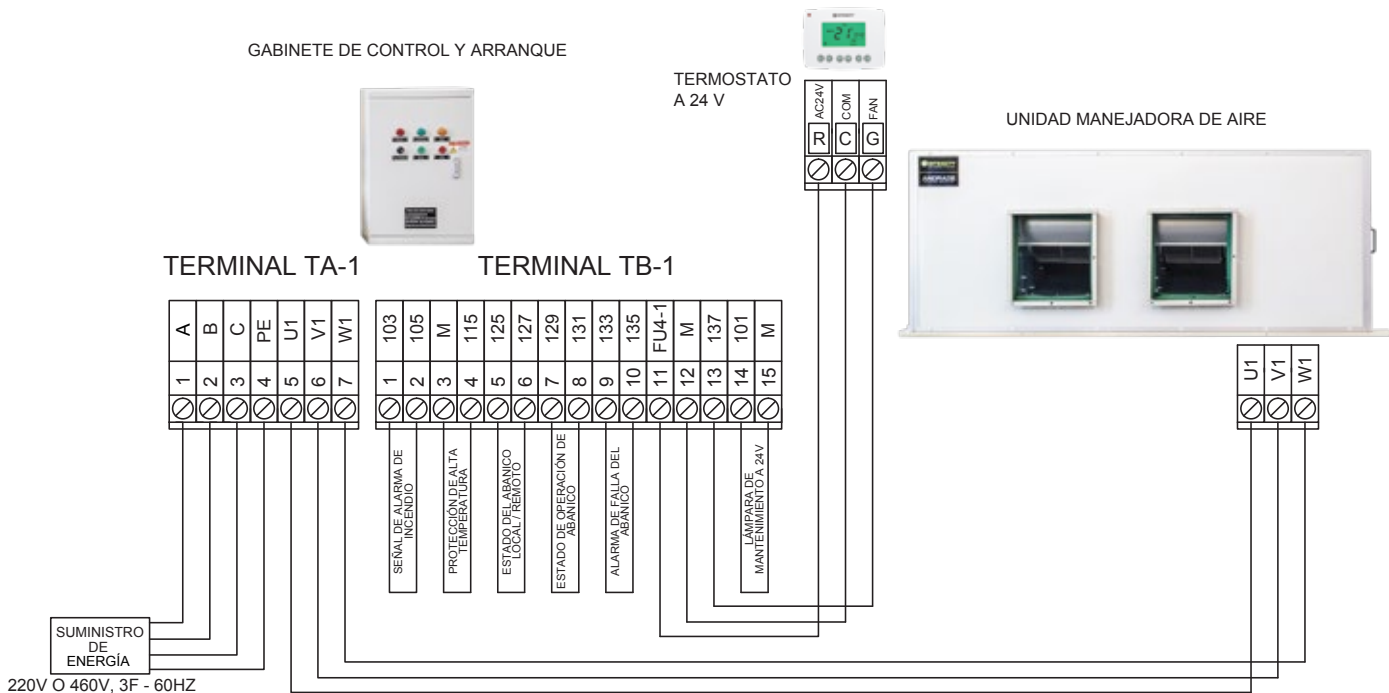

*Imágenes con fines ilustrativos.

Dimensiones de unidad

IAHWH-06KF-5/6

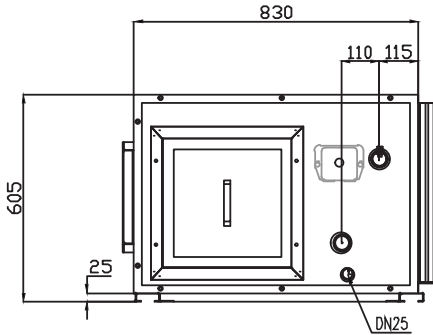

Vista Lateral Derecha

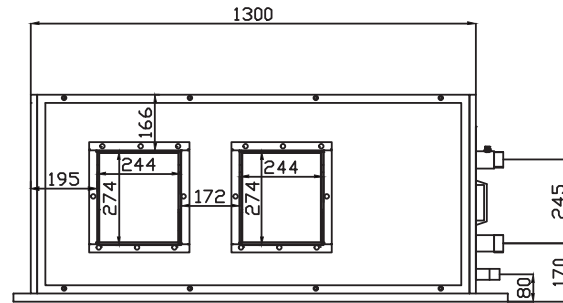

Vista Frontal

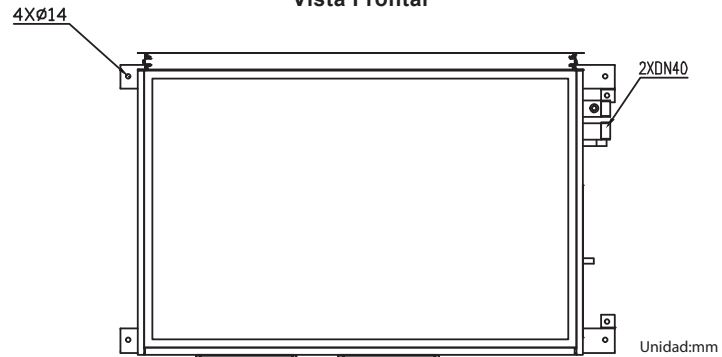

Vista Superior

IAHWH-08KF-5/6

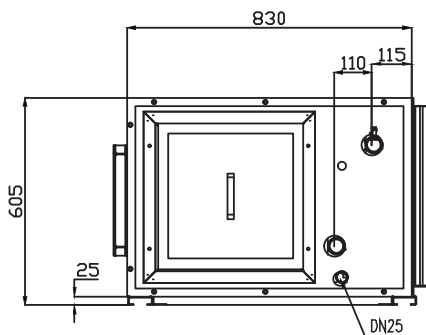

Vista Lateral Derecha

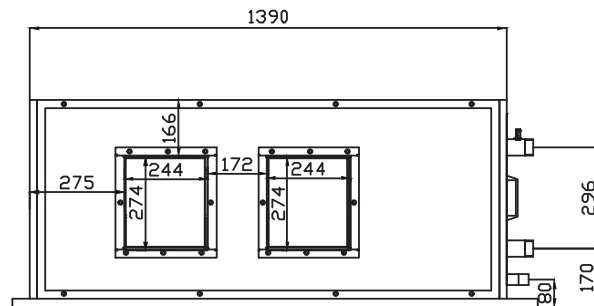

Vista Frontal

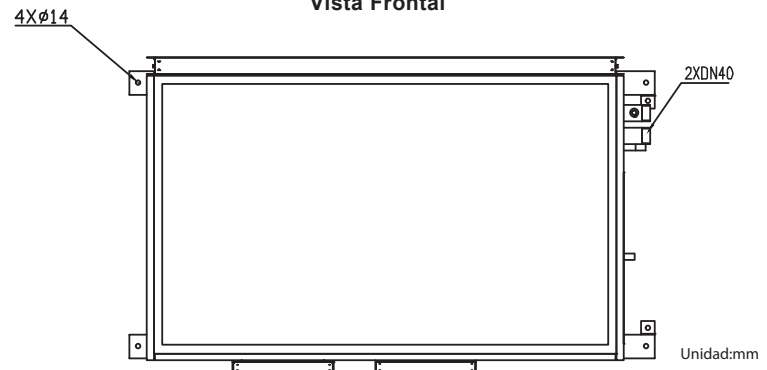

Vista Superior

*Imágenes con fines ilustrativos.

El fabricante se reserva el derecho de modificar las características de los equipos, sin previo aviso.

✓ Dimensiones de unidad

IAHWH-12KF-5/6

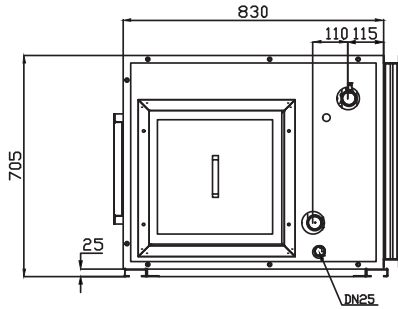

Vista Lateral Derecha

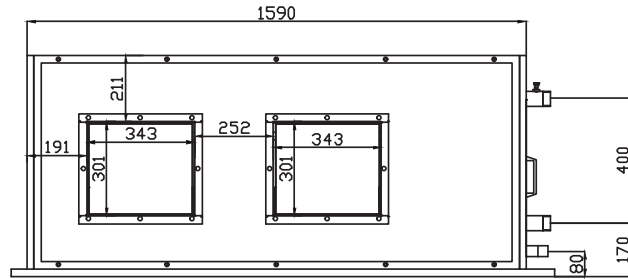

Vista Frontal

4XØ14

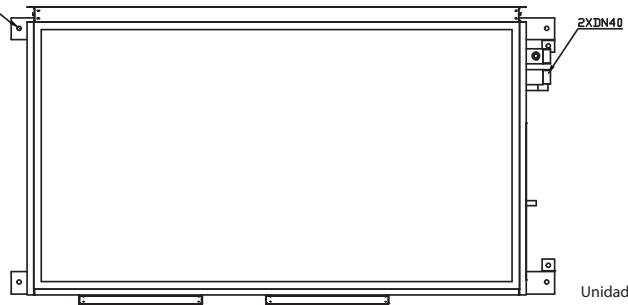

Vista Superior

IAHWH-14KF-5/6

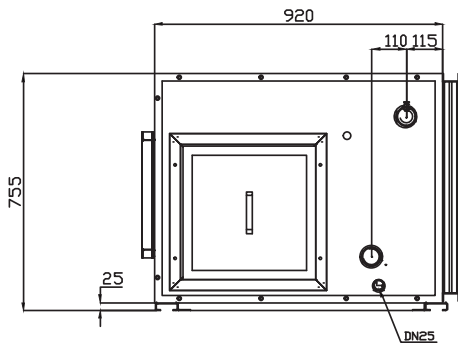

Vista Lateral Derecha

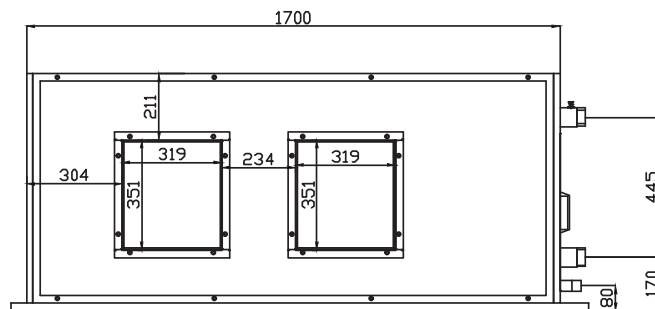

Vista Frontal

4XØ14

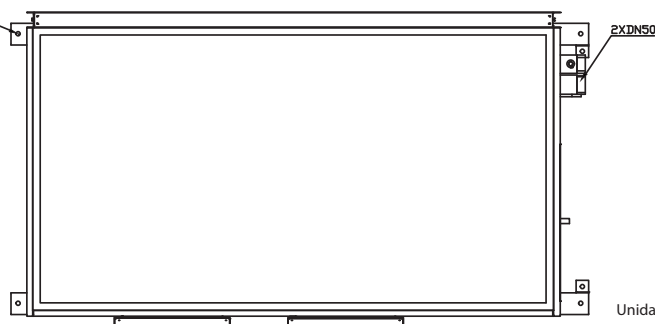

Vista Superior

*Imágenes con fines ilustrativos.

Dimensiones de unidad

IAHWH-16KF-5/6

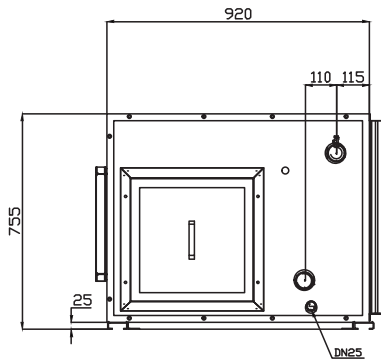

Vista Lateral Derecha

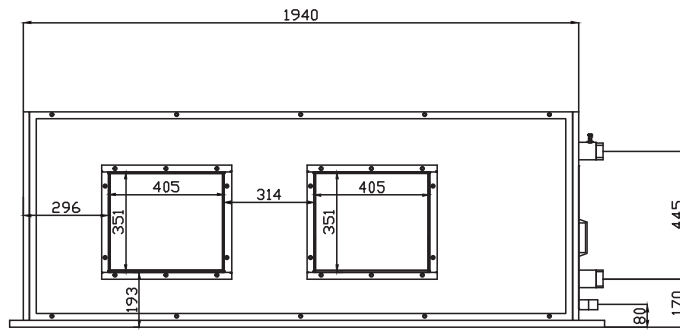

Vista Frontal

4XØ14

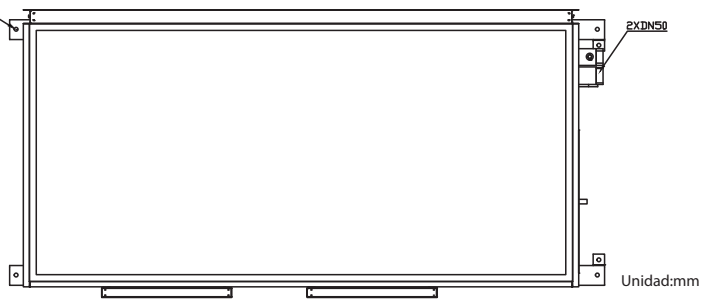

Vista Superior

Unidad:mm

IAHWH-24KF-5/6 IAHWH-28KF-5/6 IAHWH-34KF-5/6

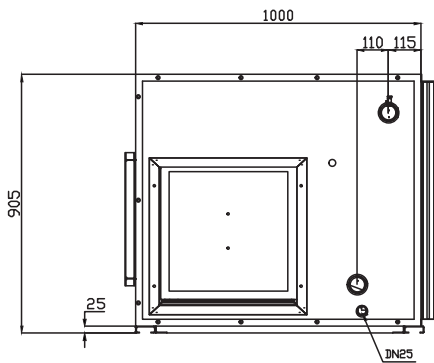

Vista Lateral Derecha

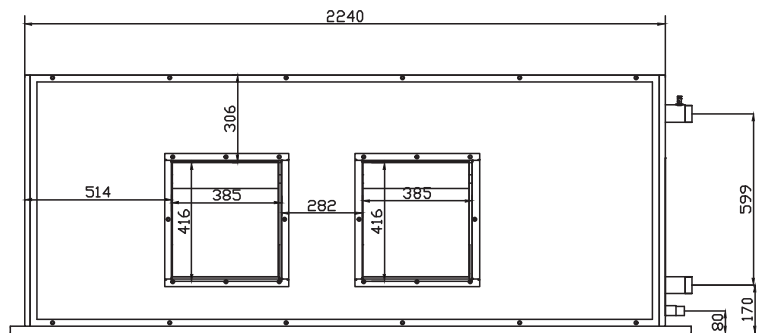

Vista Frontal

4XØ14

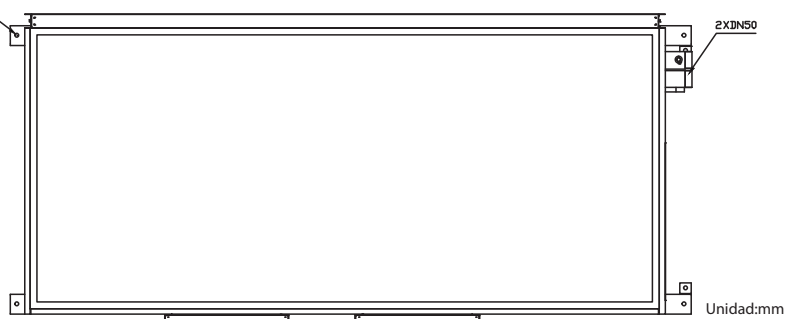

Vista Superior

Unidad:mm

*Imágenes con fines ilustrativos.